

C. G. SINGER.
Machine for Branding Barrels.

No. 220,997.

Patented Oct. 28, 1879.

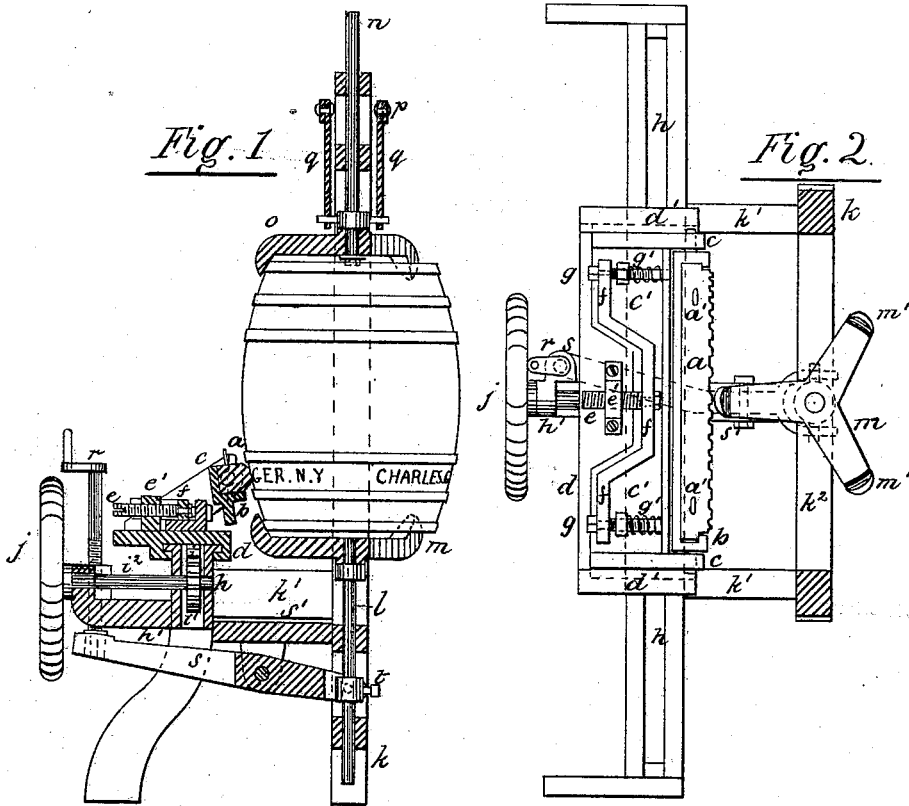

Witnesses.

A. G. Holcombe
H. Williams

Charles G. Singer
Inventor
per Alfred Theobald
attf.

C. G. SINGER.
Machine for Branding Barrels.

No. 220,997.

Patented Oct. 28, 1879.

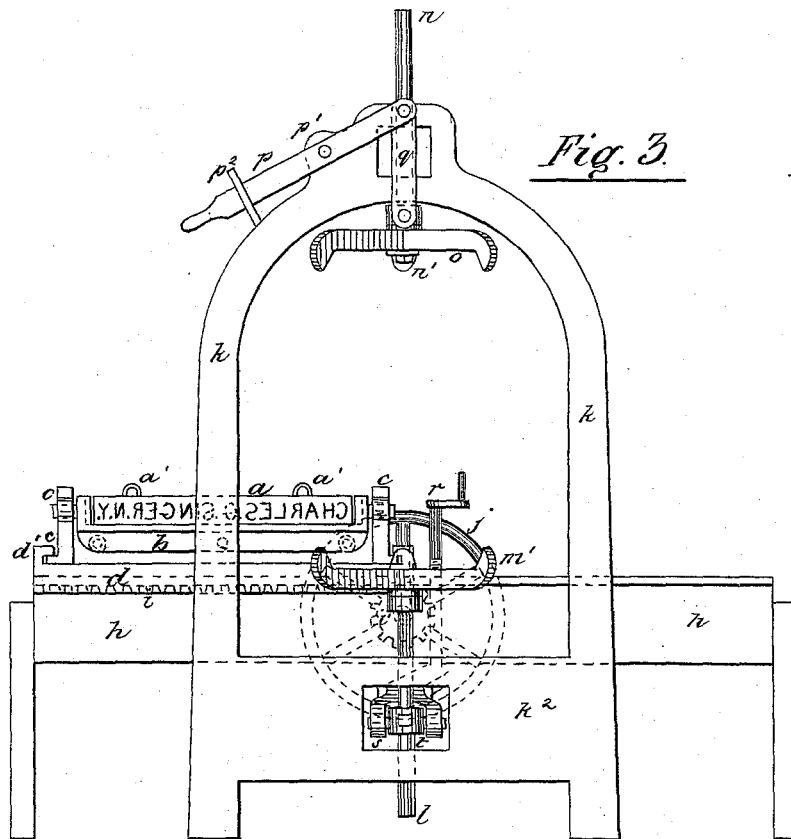

Fig. 3.

Witnesses.

A. G. Holcomb
H. D. Williams

Charles G. Singer
Inventor
per Alfred Sherlock
att'y.

UNITED STATES PATENT OFFICE.

CHARLES G. SINGER, OF NEW YORK, ASSIGNOR OF ONE-HALF OF HIS RIGHT
TO JOSIAH H. MACY, OF HARRISON, N. Y.

IMPROVEMENT IN MACHINES FOR BRANDING BARRELS.

Specification forming part of Letters Patent No. **220,997**, dated October 28, 1879; application filed
June 24, 1879.

To all whom it may concern:

Be it known that I, CHARLES G. SINGER, of the city of New York, county and State of New York, have invented a certain new and useful Machine for Branding Barrels, of which the following is a specification.

Barrels, casks, and similar articles have heretofore, when it is required to indelibly mark them, been so marked on the flat heads by means of flat burning-brands, which method of marking is not a sure guarantee to the brewer and others who use barrels, &c., to convey their goods to the consumer that they will be returned when empty, as many dishonest persons knock out the marked heads and replace them by new unmarked or differently marked ones, so that it is impossible for the brewers or manufacturers to recognize their own barrels, &c. Now, the machine which is the subject of this invention has for its object to prevent such fraudulent practice by providing means for readily burning the letters or private marks in the staves nearly or entirely around the central portion of the barrel or between the hoops, so that the whole barrel would have to be destroyed to obliterate the brewer's or manufacturer's name or private mark; and it consists of a branding-iron pivoted in a carriage at its ends, thus allowing it to adjust itself to the varying inclination of the sides of different barrels. The branding-iron, being heated before it is placed in the machine, is held against the barrel by springs, so as to accommodate it to any inequalities on the surface of the barrel, which is held between two centering-spiders free to revolve on short shafts in line with each other, the lower shaft being vertically adjustable by means of a lever, so as to bring the barrel in proper position to be branded. The carriage, when moved along on its bed with the yielding branding-iron, causes the barrel to rotate on its axis by the letters being burned into the staves; but to more fully describe my invention and the manner of using the same, I will refer to the accompanying drawings, forming part of this specification, in which—

Figure 1 is a transverse sectional elevation, showing the barrel in position to be branded.

Fig. 2 is a plan view with part of the frame in section, and Fig. 3 is an elevation looking toward the face of the brand and with the barrel removed.

The brand *a* consists of a bar of copper or cast-iron with raised reverse letters of the name to be branded on the barrel along one side of it, and it is provided on the top side with the two staples *a' a'*, by means of which it is placed in a suitable furnace to be heated, and from thence into the brand-holder *b*, which has trunnions at its ends fitting into the bearings *c c* of the frame *c'*. This brand-holder *b* is weighted at the under side sufficiently to maintain the face of the letters on the brand in a vertical position, or nearly so, but allowing the letters to adapt themselves to the inclination of the side of the barrel when brought in contact therewith.

Instead of using a separate pivoted brand-holder the brand itself may be provided with trunnions at its ends, arranged to fit into open bearings on the frame *c'*.

The frame *c'* is held on the carriage *d* by means of the guides *d' d'*, but is free to move transversely thereon, which transverse movement is controlled by the screw *e*, working in the nut *e'*, attached to the carriage *d*, the inner end of the screw *e* being secured to the bent bar *f* by means of a nut on its extreme end, which allows the screw to rotate, but causes the bar *f* to move with it.

At the ends of the bar *f* are secured the two bolts *g g*, which extend through a rib on the frame *c'*, and the springs *g' g'* on the bolts *g g* hold the rib against the heads of the bolts, the strength of the springs being regulated by the adjusting-nuts on the central part of the bolts. The position of the frame *c'* is thus governed by the screw *e*, and the branding-iron *a* is held up to its work by the springs *g'*.

The carriage *d* is constructed to slide on the top of the bed *h* in a similar manner to the carriage of a lathe on its shears, and it is caused to move from one end to the other of the bed by means of the rack *i*, secured to the under side of it and meshing into the pinion *j'*, secured to the shaft *j*, fitted to turn in bearings in the center of the bed *h* and in the

bracket *h'*. It is operated by the hand-wheel *j*, secured to its end, which projects beyond the bracket *h'*.

The arched frame *k* is secured to the front of the bed *h* (or that side of it to which the brand *a* faces) by the short girders *k' k'*, and in bearings provided in the part *k²* of the frame is fitted the vertical shaft *l*, on the upper part of which, and supported by a collar thereon, is placed the three-armed spider *m*, on which the barrel to be branded is placed, and held in a central position thereon by the inclined projections *m' m'* on the ends of the arms of the spider *m*, which incline projections properly center all barrels whose end diameters are not less than the diameter of the circle embracing the lower part of the inclined projections, nor larger than the diameter of the circle embracing their upper parts.

In bearings provided in the upper part of the frame *k* is fitted the shaft *n*, which is in line with the shaft *l*, and against a collar on the lower end of this shaft is fitted a centering-spider, *o*, similar in every respect to the spider *m*, it being held up on the shaft *n* by means of the nut and washer *n'*. Both the spiders *m* and *o* are free to revolve on their respective shafts, and the upper one, *o*, is let down, so as to embrace the top of the barrel placed on the lower one, *m*, and raised therefrom to allow the barrel to be removed by means of the forked hand-lever *p*, pivoted to the frame *k* at *p'*, and connected to the collar on the shaft *n* by the links *q q*.

The barrel is adjusted vertically, so as to apply the brand in the part of it desired, which is shown in the drawings as being between two of the hoops, that being the part I prefer to brand, as being less liable to get marred; but said branding, when desired, may be on the central portion of the barrel by changing the position of the barrel-holding device. This vertical adjustment of the barrel is effected by means of the vertical screw *r*, which fits in a correspondently-tapped hole in the side of the bracket *h'*, the lower end of the screw resting on the outer end of the lever *s*, which works on a bolt between lugs projecting down from the short central girders *s'*. The other end of the lever *s* is forked and surrounds the collar *t*, to which it is connected by short studs. The collar *t* fits on the vertical shaft *l*, and is secured thereto by a set-screw, so the position of the barrel may be roughly arranged by adjusting the collar on the shaft, and then set to the exact position by turning the crank on the top of the screw *r*.

The operation of the machine is as follows, assuming the various parts of the machine to be in the position shown in Fig. 3—that is, the carriage with the brand at one end of the bed and the hand-lever *p* pressed down under the spring *p²*, so as to hold the upper spider, *o*, out of the way: A barrel is placed on the lower spider, *m*, and the hand-lever released to allow the upper spider to fall by its own weight over the upper end of the barrel, where it rests

and brings the center of the barrel in line with the shafts *l* and *n*. The brand *a*, heated in a suitable furnace, is then placed in the brand-holder and the carriage caused to travel to the other end of the bed *h*, thus bringing the face of the brand in contact with the barrel, which causes the barrel to turn round as the brand is moved along, the frame holding the brand being set sufficiently forward by the screw *e*, so that the springs *g' g'* are somewhat compressed, thus holding the brand against the barrel with a yielding pressure.

If it is desired to mark all around the barrel and the length of the brand is only sufficient to mark half-way round it, then, when the carriage reaches the other end of the bed, the barrel is turned half-way round by hand and the carriage moved back, which completes the branding. The barrel is then removed and another placed in the machine and the operation repeated, the brand being retained as long as it is sufficiently hot to turn the barrel, when it is replaced by a fresh-heated brand.

At Fig. 1 is shown the largest size barrel in position that the machine is capable of branding. For smaller barrels the brand-frame is set out toward the center of the barrel-holding device by turning the screw *e*, and the spiders *m* and *o* are replaced by smaller ones if the ends of the barrel are less than the smallest part of the spiders, or the inclined projections on the spiders may be made separate from the arms of the spiders and adjustable thereon.

It is obvious that with very slight modifications in the construction of the machine the motive power may be applied to the barrel-holder to cause it to turn, which would move the brand along by its contact with the barrel instead of applying the motive power to move the brand, as described.

Having now described my invention, what I claim is—

1. In a barrel-branding machine, the combination of the pivoted brand, supported on a sliding carriage, with a device for holding the barrel, the axis of which is at right angles to the travel of the brand-carriage, substantially in the manner hereinbefore set forth.

2. The vertically-adjustable barrel-holder, in combination with a brand or brands operated, substantially in the manner described, so as to raise the barrel into position to allow the impression to be made around the staves of the barrel, as hereinbefore set forth.

3. The brand-holder *b*, provided with trunnions at its ends, upon which it is free to oscillate, in combination with the removable brand *a*, provided with the staples *a' a'*, substantially as and for the purpose hereinbefore set forth.

4. In combination, the pivoted brand, the frame *e'*, screw *e*, bar *f*, and spring-bolts *g' g'*, substantially as and for the purpose set forth.

5. The frame *e'*, in combination with the carriage *d*, bed *h*, and adjustable spring-connections *e f g g'*.

6. The yielding pivoted brand *a*, in combi-

nation with the barrel centering and holding spider-frames *m* and *o*, free to revolve on their respective shafts, substantially as hereinbefore set forth.

7. The bar-shaped brand *a*, having the letters on one of its sides, and pivoted at its ends in a suitable frame, in combination with springs, all substantially as described, and arranged in such a manner as to cause the entire length of the brand to bear against the barrel with a yielding pressure, so that all parts of the faces of the letters come in contact with the sides of the barrels as the brand is moved longitudinally in direction at right

angles to the axis of rotation of the barrels, substantially as hereinbefore set forth.

8. The combination of the brand *a* with the spider *m*, shaft *l*, lever *s*, and vertical screw *r*, whereby the barrel resting on the spider is vertically adjusted, so as to bring the part to be branded opposite the letters of the brand, substantially as hereinbefore set forth.

In witness whereof I have hereunto set my hand this 23d day of June, 1879.

CHARLES G. SINGER.

Witnesses:

JOSIAH H. MACY,
ALFRED SHEDLOCK.